



**fds** consult

## **LD1 Hob Detection Concept Explained**

**Application to Apartments**

Issue 02

Feb 2017

## **CONTENTS**

- 1.0 INTRODUCTION
- 2.0 ANALYSIS OF THE PROBLEM
- 3.0 STANDARDS
- 4.0 LD1 HOB DETECTION CONCEPT
- 5.0 APPLICATION OF THE CONCEPT
- 6.0 SYSTEM COMPONENTS
- 7.0 CONCLUSIONS

APPENDIX A – LD1 HOB DETECTION MARKETING PAGE

APPENDIX B – HOB GUARD PRODUCT REVIEW

APPENDIX C – SUMMARY OF RESIDENTIAL SPRINKLER RESEARCH

This report has been prepared for the sole benefit, use and information of DM Solutions Ltd and the liability of FDS Consult Limited, its Directors and Employees in respect of the information contained in the report will not extend to any third party.

Issue	Date	Amendment Details	Author	Checked
00	12/02/16	Initial report for comment	DS	HS
	12/02/17	Report updated	DS	HB
<b>Distribution</b>				
DM Solutions Ltd www.dmsolutions.co.uk				

© **FDS Consult Limited**

This report is formulated on the basis of the information and experience available at the time of preparation. It is applicable to the above-mentioned project only in accordance with the client's instructions. It is only valid provided no other modifications are made other than those for which a formal opinion has been sought and given by FDS Consult Limited.

FDS Consult Limited  
 152-154 London Road  
 Greenhithe  
 Kent  
 DA9 9JW

Tel: +44 (0) 1322 387411  
 Fax: +44 (0) 1322 386361  
 Web: www.fdsconsult.com

## 1.0 INTRODUCTION

This report is intended to document the 'LD1 Hob Detection' concept and provide justification on its application for apartments in high rise residential buildings. This will give Designers greater flexibility on the application of the various Codes by the addition of a LD1 Hob Detection System as a compensation feature to manage the hob risk.

Residential fires as below are a constant problem and as living concepts have changed over the years, the various codes minimise the flexible layout requirements of Designers.

This report is intended to provide an overview on the additional measures which can be provided to improve safety and provide greater flexibility in the application of the Codes as part of an engineered solution.

## 2.0 ANALYSIS OF THE PROBLEM

Analysis on fires in England is documented by the Department for Communities and Local Government and is based upon statistical information provided by the Local Authority Fire and Rescue Services.

The April 2014 to March 2015 statistics provides the following headlines:

- There were 258 fire fatalities in England in 2014 to 2015.
- 63 per cent of all fire fatalities were in accidental dwelling fires.
- There were 3,235 non-fatal fire hospital casualties.
- Local authority fire and rescue services attended around 154,700 actual fires in England in 2014 to 2015.
- 44 per cent of all incidents attended were fire false alarms.
- There were 28,200 accidental dwelling fires.
- 61 percent of domestic fires occurred in the kitchen.
- 52 percent of domestic fires were caused by the cooking appliances.

It can be concluded from the above that the cooking appliances account for the majority of domestic fires in England. Unfortunately, this is not broken down further between hobs and ovens, but from conversation with experienced fire fighters the majority reference hobs as the greater risk. This is further documented on Fire Brigade Organisations web sites which have campaigns for kitchen fires which concentrate on hob fires.

The fires identified in the above statistics would be within domestic properties constructed in accordance with the Building Regulations. This includes kitchen compartmented properties, open plan properties and studio properties.

It is clear from the above statistics that additional measures should be provided to minimise cooking appliance fires, which would reduce the above figures and allow greater trade-offs for open plan and studio properties.

### 3.0 STANDARDS

The Building Regulations drive the requirements for apartment layouts in England & Wales. Guidance on meeting these regulations in apartment buildings is outlined in the Approved Document B (ADB) and the British Standard BS9991:2015 Fire Safety in the design, management and use of residential buildings.

The relevant section 2.13 in ADB provides typical guidance for apartment layouts in high rise residential blocks as outlined below:

- *To plan the flat so that the travel distance from the entrance door to any point in any of the habitable rooms does not exceed 9m and the cooking facilities are remote from the entrance door and do not prejudice the escape route from any point in the flat, OR*
- *To provide a protected entrance hall which services all habitable rooms, planned so that the travel distance from the entrance door to the door to any habitable room is 9m or less.*

This document generally accepts that a Grade D, Category LD3 detection system in accordance with BS5839 Part 6:2004 is an acceptable level of detection.

The relevant section 9.4.2 in BS9991:2015 provides typical guidance for apartment layouts in high rise residential blocks as outlined below:

- *The total travel distance from any point of the flat to the entrance door of flat should be limited to 9m. Cooking facilities should be sited away from the flat entrance door and the internal escape route.*
- *A protected internal hallway should be provided that leads off to all habitable rooms having a travel distance not exceeding 9m from the flat entrance door to the door of any habitable room.*

This document generally accepts that a Grade D, Category LD3 detection system in accordance with BS5839 Part 6:2004 is an acceptable level of detection.

Section 9.7 in BS9991:2015 provides additional guidance for a new concept called 'Open Plan Flat Design' as below:

*Open plan flats do not have protected corridors or hallways but have bedrooms that are inner rooms without having an alternative means of escape, and that are accessed directly from a lounge or similar accommodation, should be fitted throughout with a Grade D LD1 fire alarm and fire detection system in accordance with BS 5839 Part 6:2013 and an automatic sprinkler system.*

*Open plan flats should meet the following specific recommendations:*

- *The size of the open plan flat should not exceed 16m x 12m.*
- *Open plan flats should be situated on a single level only.*
- *The ceilings within the open plan flat should have a minimum height of 2.25m.*
- *The kitchen should be enclosed in open plan flats having an area exceeding 8m x 4m. Cooking appliances in open plan flats having an area smaller than 8m x 4m should not be adjacent to the entrance of the flat.*

### 3.1 ANALYSIS OF THE STANDARDS TO APARTMENT DESIGNS

The ADB and BS9991 provide general guidance on acceptable travel distance and the measures required where these distances are followed.

The ADB guidance does not address the benefits of sprinklers which may be installed in buildings exceeding 30m in height or the advantages of additional detection to raise the alarm earlier.

The BS9991 does recognise the benefit of sprinklers and allows some trade-offs where an improved level of detection is provided.

The general conclusion identifies the cooking facilities as the high risk element and the restrictions are based around this by requesting the cooking facilities are remote from the escape area. This remote distance seems to be open to interpretation. Some organisations have adopted the 1.8m distance as outlined in section 5.24 of ADB which is based upon no science and does not consider the benefit of sprinklers or early detection. Other organisations then add 0.75m to this distance and set the distance to 2.55m.

### 4.0 LD1 HOB DETECTION CONCEPT

The LD1 Hob Detection concept was developed based around the kitchen risks and raising an alarm throughout the apartment so the occupants are aware of the incident earlier allowing them to evacuate safely in the early stages of a fire.

Local detection is provided 600mm above the hob which during 'monitor mode' raises a pre warning 15 second alarm where conditions at the hob are changing, drawing the Occupants attention to the problem and allowing them reset the unit and manage the issue.

If no action is taken within this period or conditions deteriorate, the system enters 'fire mode' with the power supply to the hob isolated removing the risk of ignition. At the same time all the apartment sounders are activated in all the rooms.

This concept warns the Occupant earlier so they can manage the hob condition. The concept allows the occupants to be notified earlier ensuring they start moving earlier compared to a traditional detection system where the incident needs to have occurred with the heat rising to the ceiling mounted heat detector which could be minutes after the fire has occurred.

The concept involves a number of components which have a function as outlined below:

#### 4.1 Hob Guard Detection

The Hob Guard comes from Norway & Finland where they have years of experience of kitchen fires. Their Building Regulations require hob guards to be fitted to hobs to prevent fires for typical cooking processes.

Hob Guard has been tested for compliance with the British Standard BSEN50615 'Household and similar electrical appliances – Safety – Particular requirements for devices for fire prevention and suppression for electrical hobs' by SP Fire Research ([www.spfr.no/services/fire-testing/stove-guards](http://www.spfr.no/services/fire-testing/stove-guards)). SP Fire Research is the largest independent research organisation in Norway similar to the BRE in England. The unit is also CE marked in accordance with the EC directives.

The Hob Guard prevents hob fires occurring by constantly monitoring the hob using sophisticated algorithms which can identify between safe and unsafe cooking practices and avoid false alarms.

In 'monitor mode', the system will initially sound a 15 second sounder at 65dBa if it is getting too hot, temperatures rising too quickly, unusual electrical current change, or the hob is left unattended with no cooking source. If no action is taken within the 15 seconds, the system will go into 'fire mode' by automatically turning the hob off with the sounder continuing to operate. Where the sounder activation is due to an unusual cooking process, the Occupant simply presses the reset button on the Hob Guard above the hob allowing the system to be reset and continues monitoring the hob. The Occupant is managing the process with the necessary audible alarm provided warnings as necessary.

Hob Detection works by monitoring the hob constantly for cooking activity as shown in Figure 1. This includes infrared for monitoring radiant & conducted energy, time, power consumption, movement combined with sophisticated algorithms as required by the BS EN Standard.

Based on the data from the sensors, the Hob Detection recognises both cooking and hazardous situations and reacts accordingly so as not to interrupt the normal cooking process.

The unit is manually reset after activation and ready to protect the hob again unlike suppressant system which would require recharging, which rarely occurs.

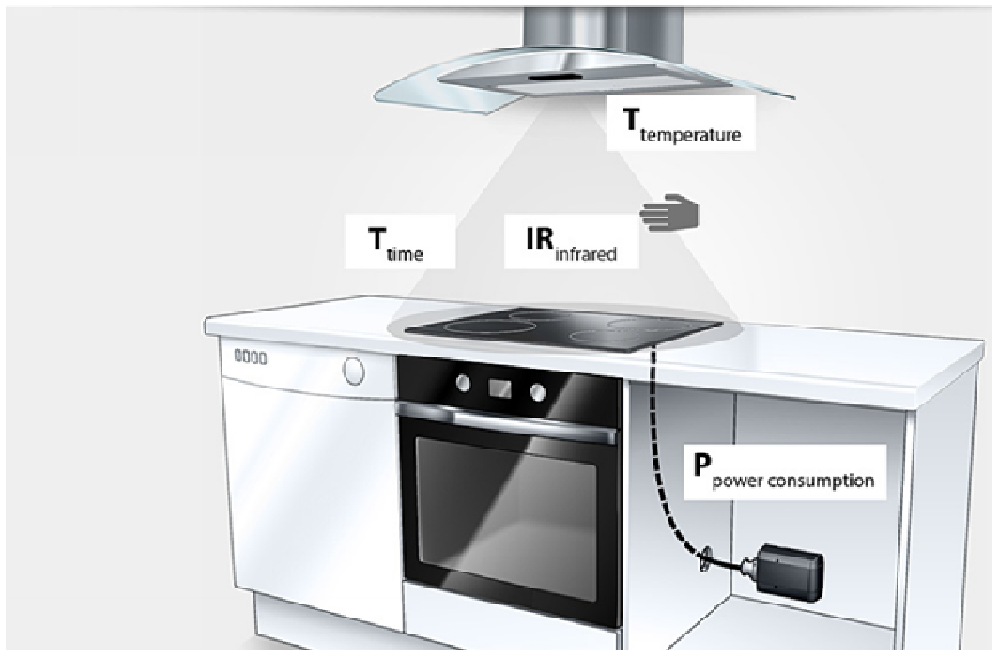

**Figure 1 – Sensing Elements**

A graphical demonstration of the sensors can be seen in the '[Hob Guard Intelligence Video](#)'. ([www.dmsolutions.co.uk](http://www.dmsolutions.co.uk)).

A demonstration of the system operating compared to a traditional unmonitored hob, to prevent a fire occurring can be seen in the '[Hob Guard Fire Video](#)'.

Our research indicated the Hob Guard/Detection is already installed in thousands of kitchens across Europe and since these installations, none of the owners have ever reported a hob fire. Hob Guard does not interfere with normal cooking and doesn't require any maintenance, other than a quick clean of the sensor from time to time. A full review of the unit is documented in the FDS Consult Report 'Kitchen Hob Protection Review Concept' in Appendix B of this report.

In summary the Hob Guard is provided to protect the hob, which will isolate the power to the hob, where the 15 seconds warning is ignored, prior to ignition occurring in accordance with the British Standard BSEN 50615. As the detection unit is located 600mm above the hob, it provides local detection to the hob. The hob guard unit will sound the unit alarm and activate the LD1 sounders to raise the alarm in all rooms.

The unit is intended to prevent a hob fire occurring, and provides local detection to raise the alarm earlier unlike the ceiling mounted heat detector resulting in earlier notification of an incident. In an incident this could be minutes and the hob guard will have isolated the power to the hob.

## 4.2 Ceiling Mounted Detectors

Intelligent combined heat detection & sounders and smoke detection & sounders are provided throughout the apartment to provide an LD1 grade D level of coverage. The smoke detectors can be optical or Ionisation to meet the needs of the space. All detectors and sounders meet the associated standards including BS5839: Part 6 2013, BS5446: Part 2 2003 and BS EN14604:2005

The combined smoke/sounder and heat detector/sounder are linked to the Hob Detection Unit resulting in all the sounders operating on operation of the Hob Guard ensuring the alarm is raised.

The provision of the sounders will improve the detection times and audibility throughout the apartment resulting in the sounders operating to achieve an earlier evacuation time.

## 4.3 LD1 Hob Detection Control Unit

The LD1 Hob Detection Control Unit links the hob guard and detectors to ensure the fire sounders are operated throughout the apartment on operation of the Hob Guard local detector.

The LD1 Hob Detection control Unit can also be provided with floor mounted leak detectors, which can detect wetting of the floor from fire sprinklers to an apartment appliance. This can also activate the sounders throughout the apartment

The above components are shown in Figure 2 below.

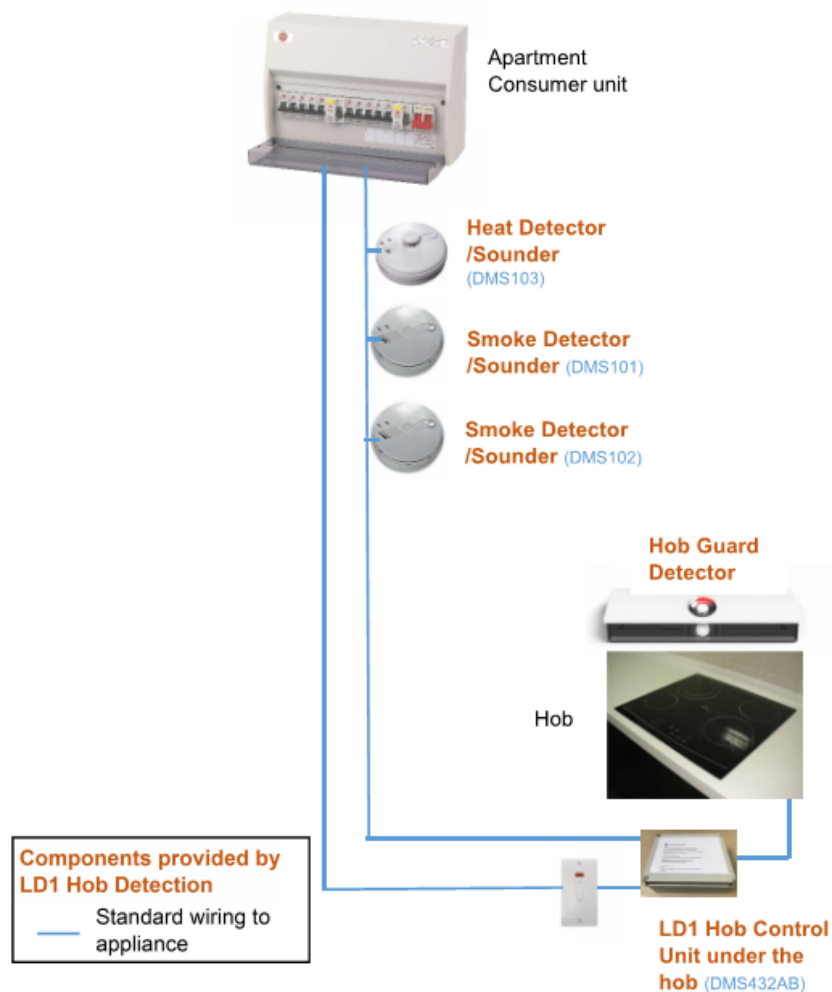

**Figure 2 – LD1 Hob Detection Concept**



## 5.0 APPLICATION OF THE CONCEPT

As identified earlier, the various codes limit the travel distance from the entrance door to any point in any of the habitable rooms to 9m and the cooking facilities need to be remote from the entrance door. This layout generally applies to Studio Apartments.

Alternatively, the apartment can be of the open plan layout where the criteria outlined above is addressed and an LD1 detection and sprinklers are provided. This concept is known as 'Open Plan Apartments'.

The following section analysis the apartment types and how the LD1 Hob Detection is applied.

### Studio Apartment

In the case of Studio type apartments, the entrance to the apartment is from the common corridor which is generally located within the centre of the building resulting in the front door at the land locked end of the apartment as shown in Figure 3 below. As people want to live by the windows for light, this generally becomes the living area where the TV and sofa are located. As a result, the cooking facility will generally be located on the back of the apartment similar to the front door as shown below.

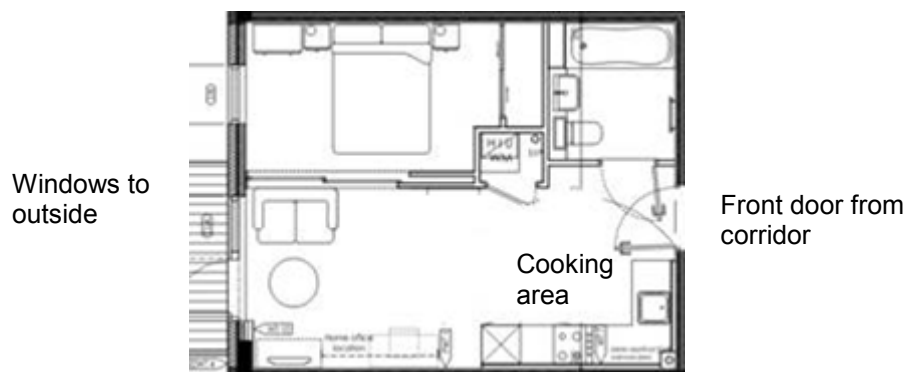

**Figure 3 – Studio Apartment**

The issue on the above apartment is escaping past the cooking area.

The LD1 Hob Detection concept would be to fit the kitchen hob with a Hob Guard and upgrade the detection system to an LD1 detection system, thus managing the risk and improving the detection time allowing evacuation to commence earlier.

The Hob Guard would isolate the power supply to the hob prior to ignition occurring in accordance with BS EN 50615 preventing a hob fire occurring. At the same time the apartment fire sounders would be activated. If for some unknown reason a hob fire did occur, the sounders would have raise the alarm earlier, allowing the occupants leave the apartment in advance of that of a code based solution. The traditional unmonitored hob would allow the fire to occur and continue to grow, delaying the time for the heat detection to react which would have a lower sound level due to the LD3 detectors.

The table below compares a code based solution over that of an engineered solution using Kitchen Guard.

	<b>ADB Code Solution</b>	<b>LD1 Hob Detection Engineered Solution</b>
Level of ceiling mounted smoke detection	LD3	LD1
Local detection 600mm above hob	No	Yes
Local detection above hob linked to ceiling mounted sounders	No	Yes
Isolation of hob power in accordance with EN50615 prior to ignition	No	Yes
Fire Sounders raised earlier due to local hob detection	No	Yes
Evacuation commences earlier prior to hob fire growing unnoticed	No	Yes
Location of hob critical	Yes	No

The LD1 Hob Detection which is designed to prevent a hob fire occurring, provides local detection which raises the alarm throughout the studio apartment earlier providing a higher standard of safety to the code and allowing the Designers the flexibility on the cooking appliance location.

## Open Plan Apartment

In the case of Open Plan Apartments, the entrance to the apartment will be to an open area with the habitable rooms located off the general area as typically shown in Figure 4 below. The apartment will be provided with an LD1 detection system and a residential sprinkler system. The rooms will be separated from the open area by non fire rated partitions.

As identified earlier, the BS9991:2015 requires the kitchen to be enclosed where the apartment area is greater than 8m x 4m (32m<sup>2</sup>). The document goes on to state that in apartments smaller than 8m x 4m, the cooking appliances should not be adjacent to the entrance to the apartment, similar to Studio Apartments.

The previous BS9991, 2011 edition allow the kitchen area to be open plan up to 80m<sup>2</sup> which was based upon the NHBC Open Plan Research Work.

As can be seen from all the various guidance, the cooking appliances are seen as the risk element which sets the standards.

With modern living, Occupants wish to have a large open plan space incorporating living area, kitchen and dining space to form a free flowing open space as shown in Figure 4 below. This is common living in non UK Countries. Unfortunately, this is not always possible as a result of the 32m<sup>2</sup> guidance.



**Figure 4 – Open Plan Apartment**

We understand the thinking behind the reduction in the open plan area is to do with limiting the travel distance in the open space as a result of the hob making escape safer within the escape route.

In the lead-up to the publication of the ADB 2006, the BRE was commissioned by the Office of the Deputy Prime minister (ODPM) in 2002 to carry out a two and a half-year study of the effectiveness of sprinklers in residential premises which was published in 2004. The BRE Research Report 204505 compared sprinklered and unsprinklered living rooms 4m by 3.2m by 2.4m high to review the effectiveness of sprinklers. A summary of the research is provided in Appendix C of this report.

The reports general conclusions were as follows:

- For the unsprinklered fires, the fire damaged area was greater than when sprinklered.
- With sprinklers, the fire gases were cooled sufficiently that the occupants of the room of origin would not have experienced extreme pain due to convected heat.
- Loss of consciousness would not have occurred in the standard lounge with the door open, but would have occurred with the door closed. In all the sprinklered fires, death would not have occurred.

- In all the fires (with and without sprinklers), visibility was lost after 5 to 7 minutes. Sprinkler activation therefore had no effect on the visibility.
- The life safety benefits of fitting smoke alarms were demonstrated. This includes the added benefit of fitting linked smoke alarms in both rooms and circulation spaces.
- Tenable conditions (apart from visibility) for the rest of the house could be maintained by the sprinklers in the room of origin, or closing the door of the room of origin.
- Without sprinklers, it was estimated that occupants of the lounge would have lost consciousness, due to convected heat, and loss of consciousness due to asphyxiant would have occurred within 1 to 2 minutes of each other. Death would follow about 1 minute after loss of consciousness. These observations were independent of the lounge door being open or closed.

The above conclusions demonstrated that the sprinklers reduced gas temperatures at head height, 2m from the fire to approximately 65°C in the fire compartment with the smoke detector operating after 2 minutes. The visibility was maintained up to 5 minutes into the fire in the small living room with a plan area of 12.8m<sup>2</sup>.

During the revisions to the ADB in 2006, the omission of door closers to internal fire doors to protected corridors was introduced, regardless if the space was sprinklered or unsprinklered. This effectively resulted in doors left open forming one large apartment.

As the fire statistics show, the kitchen area is high risk, the fire sprinklers will do little to prevent the fire occurring or raising the alarm in the early stages. The issue with the kitchen size can be resolved by treating the fire risk at source by using the Hob Guard Detection which will isolate the fire risk and if this was to fail, the sounders would be raised on the local detection providing an improved detection time to conventional ceiling mounted detectors.

The bedrooms are separated from the living area by non fire resistant construction. As each space is provided with detection, the alarm would be raised earlier allowing the occupants to leave the apartment earlier. The open plan space will allow the smoke to dilute, allowing greater visibility to a small space.

As door closers are not fitted to a traditional apartment, the doors could be left open similar to an open plan layout with no sprinklers or LD1 Hob Detection.

The table below compares a BS9991 code based solution over that of an engineered solution using LD1 Hob Detection.

	<b>BS9991 Code Solution</b>	<b>LD1 Hob Detection Engineered Solution</b>
Level of ceiling mounted smoke detection	LD1	LD1
Local detection 600mm above hob	No	Yes
Local detection above hob linked to ceiling mounted sounders	No	Yes
Isolation of hob in accordance with EN50615 prior to ignition	No	Yes
Isolation of power supply to oven	No	Yes
Evacuation commences earlier prior to hob fire growing unnoticed	No	Yes
Location of hob critical	Yes	No
Sprinklers to apartment	Yes	Yes
Smoke detection in rooms off open plan space to raise the alarm	Yes	Yes
With hob guard managing the risk, the size of kitchen opening onto the living area is critical	Yes	No

The LD1 Hob Detection which is designed to prevent a hob fire occurring provides local detection which raises the alarm throughout the apartment earlier providing a higher standard of safety to the code and allowing the Designers greater flexibility on apartment size and the cooking appliance location as part of a trade off of measures.

## 6.0 SYSTEM COMPONENTS

The LD1 Hob Detection Concept is made up of a number of components as discussed earlier. The following section looks at the components in greater detail. Appendix A provides a marketing overview of the LD1 Hob Detection Concept.

### 6.1 Hob Detection LD1 Interface

The Hob Detection LD1 Interface comprises of two components. One component is located above the hob with the second component located below the worktop as shown in Figure 5 below.



**Figure 5 – Component Locations**

The Hob Detection component (A) can be located above the hob on the extractor unit or fixed to the back wall as shown in Figure 6. The battery operated unit connects with the hob control unit by way of a wireless 2-way connection designed for safety critical applications. If the power supply is lost to the sensor, batteries are removed or the unit is removed during the filter cleaning and not repositioned correctly, the hob power will be isolated within three minutes.

The hob detector measures 130mm x 45mm x 20mm deep and comes in 10 different colours.

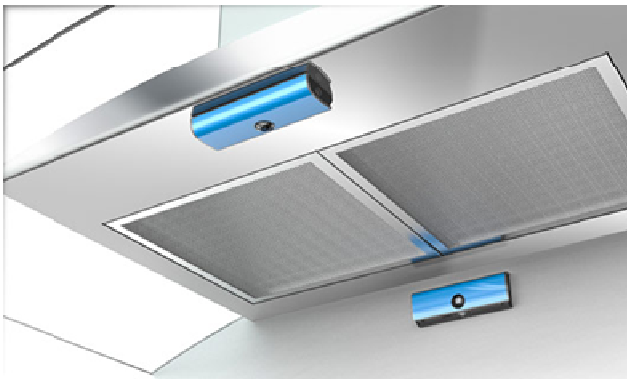

**Figure 6 – Hob Sensing Element**

The sensing unit mounting criteria are as below.

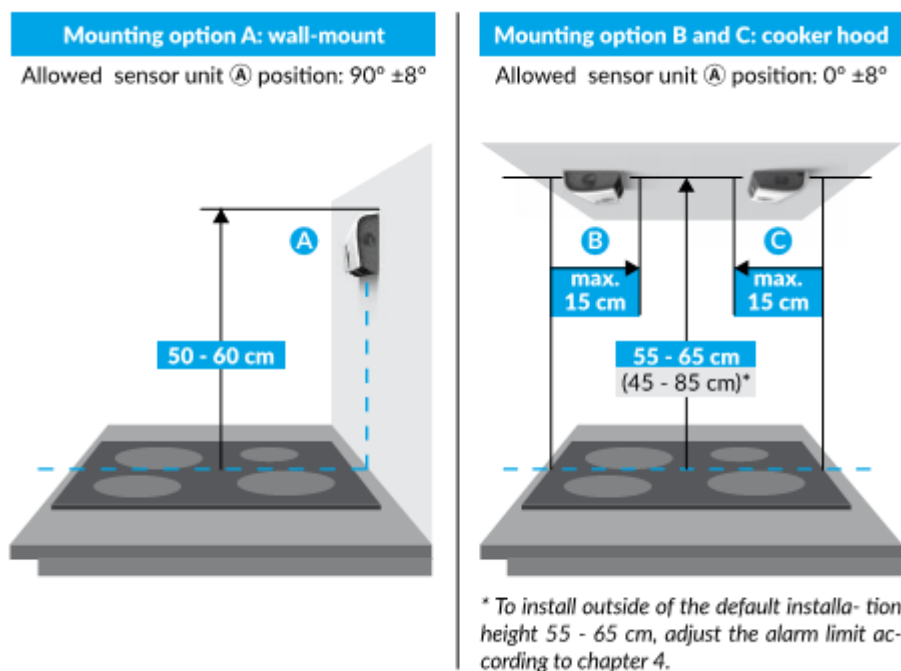

**Figure 7 – Sensing Element Position**

The electrical control component (C) shown in Figure 5 is located below the worktop and is used to monitor the current and isolate the power to the hob up to 32 amps. The unit also interfaces with the LD1 detection system to activate the DM ceiling detectors.

The local switched hob mains are wired into the control box with the output connected to the hob cable as shown in Figure 2. The device gains the necessary power from the hob cable.

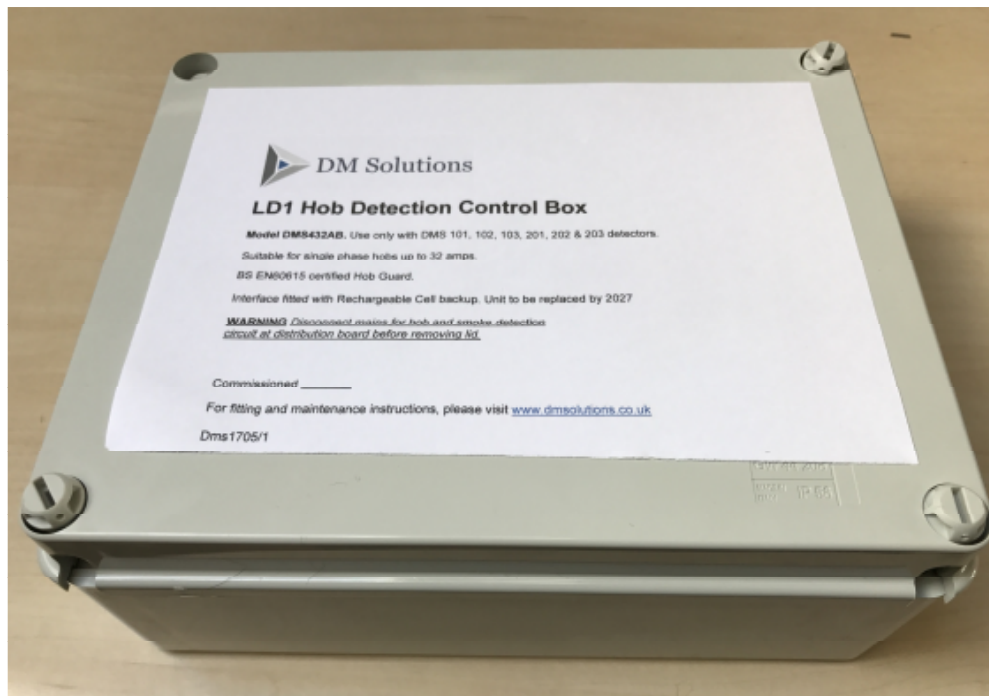

**Figure 8 – LD1 Hob Detection Box**

The LD1 Hob Detection Box measures 240 x 190 x 90mm high and can be located in cupboard adjacent to the hob or behind the kick board below the hob as shown in Figure 5.

## 6.2 Ceiling Mounted Detectors

The intelligent combined sounder heat and smoke detectors are ceiling mounted, interlinked and connected to the LD1 Hob Detection Control Box.

The following looks at the detector types forming part of the LD1 Hob Detection System.

### Optical Smoke Alarm

Optical smoke alarms are generally recommended in hallways, landings and dining rooms.

The alarm meets the BSI Kitemark to indicate type testing to BS EN14604: 2005 and meets the requirements of Grade D as defined in BS 5839 Pt.6: 2013. It carries the CE mark to indicate conformance to Low Voltage and Electromagnetic Compatibility Directives.

The alarm has an optical (photoelectric) sensor with large volume chamber and large high sensitivity photodiode. The sensor chamber has an insect resistant fine mesh screen with holes less than 0.08mm.

The unit operates on a 230V AC Mains Power Supply with battery standby supply, capable of lasting up to 4 years in standby mode and capable of powering the alarm for up to 2 years without mains power.

The alarm is supplied with an `Easi-fit` built-in surface mounting plate, with integral terminal block and cable cover. The Alarm is connected to the mains and interconnect/control connections automatically as it slides on to the mounting plate. The Alarm is disconnected from the mains and interconnect/control connections as it slides off the mounting plate, without the need for a lead and connector.

All mains wiring is covered by a cable cover so that the mains cable is not visible when the Smoke Alarm is removed from the ceiling, obviating the need for a ceiling pattress or dry lining box.

The alarm has a built-in sounder giving a minimum sound output of 85dBA at 3 metres. The diameter of the piezo disc in the sounder is 35mm and has wire contacts soldered directly on to the piezo disc.

The alarm has an interconnection capability so that if one alarm sounds all interconnected alarms sound.

The alarm has an automatic self-test feature which tests the chamber every 40 seconds and the unit beeps (without red LED flash) if it is degraded.

The alarm is provided with a manual integral test button to test circuitry, sensor and horn and activate all interconnected alarms in the system. When the test button is released, the interconnected alarms will continue to sound for 3 seconds (the alarm being pressed will stop sounding immediately) to allow the tester to hear if the other alarms are sounding. The alarm is provided with an anti-tamper locking device to prevent unauthorised removal of the alarm without the use of a tool.

The alarm is supplied with a dust cover fitted to protect it from contamination during installation.

The alarm has the following dimensions: 140mm dia. x 54mm depth.





## Ionisation Smoke Alarm

Optical smoke alarms are generally recommended in bedrooms.

The alarm meets the BSI Kitemark to indicate type testing to BS EN14604: 2005 and meets the requirements of Grade D) as defined in BS 5839 Pt.6: 2013. It carries the CE mark to indicate conformance to Low Voltage and Electromagnetic Compatibility Directives.

The alarm has a dual ionisation chamber sensor, with corrosion resistant electrodes, and insect resistant cover.

The unit operates on a 230V AC Mains Power Supply with battery standby supply, capable of lasting up to 4 years in standby mode and capable of powering the alarm for up to 2 years without mains power.

The alarm is supplied with an 'Easi-fit' built-in surface mounting plate, with integral terminal block and cable cover. The Alarm is connected to the mains and interconnect/control connections automatically as it slides on to the mounting plate. The Alarm is disconnected from the mains and interconnect/control connections as it slides off the mounting plate, without the need for a lead and connector.

All mains wiring is covered by a cable cover so that the mains cable is not visible when the Smoke Alarm is removed from the ceiling, obviating the need for a ceiling pattress or dry lining box.

The alarm has a built-in sounder giving a minimum sound output of 85dBA at 3 metres. The diameter of the piezo disc in the sounder is 35mm and has wire contacts soldered directly on to the piezo disc.

The alarm has an interconnection capability so that if one alarm sounds all interconnected alarms sound.

The alarm has an automatic self-test feature which tests the chamber every 40 seconds and the unit beeps (without red LED flash) if it is degraded.

The alarm is provided with a manual integral test button to test circuitry, sensor and horn and activate all interconnected alarms in the system. When the test button is released, the interconnected alarms will continue to sound for 3 seconds (the alarm being pressed will stop sounding immediately) to allow the tester to hear if the other alarms are sounding. The alarm is provided with an anti-tamper locking device to prevent unauthorised removal of the alarm without the use of a tool.

The alarm has a separate green LED mains indicator light to confirm integrity of mains power supply.

The alarm has a separate red LED which will flash every 40 seconds to indicate full auto test of circuitry and the rechargeable cells.

The alarm has a low power cell-warning signal, which must operate with or without mains power present.

The alarm is supplied with a dust cover fitted to protect it from contamination during installation.

The alarm shall have the following dimensions: 140mm dia. x 43mm depth.



### Fixed Temperature Heat Alarm

Heat alarms are recommended in kitchens. The alarm meets the BSI Kitemark to indicate type testing to BS 5446 Pt.2:2003 for a Class A1 device. It is CE marked to indicate conformance to BS EN 60065:1994 Low Voltage, BS EN 50081-1:1992 and BS EN 50082-1:1992 Electromagnetic Compatibility Directives.

The alarm is of the fixed temperature thermistor type, temperature range 54<sup>0</sup>C to 62<sup>0</sup>C (129<sup>0</sup>F - 144<sup>0</sup>F).

It unit operates on a 230V AC Mains Power Supply with battery standby supply, capable of lasting up to 4 years in standby mode and capable of powering the alarm for up to 2 years without mains power.

The alarm is supplied with an `Easi-fit` built-in surface mounting plate, with integral terminal block and cable cover, and removable trunking door. The heat alarm is connect to the mains automatically as it slides on to the mounting plate. The heat alarm is disconnect from the mains as it slides off the mounting plate, without the need for a lead and connector.

All mains wiring is covered by a cable cover so that the mains cable is not visible when the heat alarm is removed from the ceiling, obviating the need for a ceiling pattress or dry lining box.

The alarm has a built-in sounder giving a minimum sound output of 85dB(A) at 3 metres. The diameter of the piezo disc in the sounder is 35mm and have wire contacts soldered directly on to the piezo disc.

The alarm has an interconnection capability so that if one alarm sounds all interconnected alarms sound.

The alarm is provided with a manual integral test button to test circuitry, sensor and horn and activate all interconnected alarms in the system. When the test button is released, the interconnected alarms will continue to sound for 3 seconds (the alarm being pressed shall stop sounding immediately) to allow the tester to hear if the other alarms are sounding. The alarm is provided with an anti-tamper locking device to prevent unauthorised removal of the alarm without the use of a tool.

The alarm has a separate green LED mains indicator light to confirm integrity of mains power supply.

The alarm has a separate red LED which will flash every 40 seconds to indicate full auto test of circuitry and the rechargeable cells. The red LED will flash rapidly in alarm condition and flash once every ten seconds whilst the unit is in a de-sensitive (hush) condition.

The alarm has a low power cell-warning signal, which must operate with or without mains power present.

The alarm is supplied with a dust cover fitted to protect it from contamination during installation.

The alarm has the following dimensions: - 140mm dia. x 58mm depth.



## 7.0 CONCLUSION

The Department for Communities and Local Government statistical demonstrate that 52% of domestic fires were caused by the cooking appliances.

The British Standard BS EN50615 is relevant to preventing kitchen hob fires occurring.

The BS EN50615 standard requires the protective device to:

- raise a pre warning alarm,
- have the ability to disconnect the hob from the electricity supply before a fire starts,
- have the ability to cut off the hob electricity supply before the temperature reaches a dangerous level,
- ensure that the electricity cut-off is not triggered by a false alarm.

The LD1 Hob Detection will initially activate the hob detector for 15 seconds allowing the Occupant modify the cooking process and reset the system. Where no action is taken after 15 seconds or conditions become critical, the system will go into fire mode by isolating the power supplies to remove the fire risk and activating the LD1 sounders.

The Hob Guard detector making up part of the LD1 Hob Detection system provides a reliable method of preventing hob fires and removing the hob risk from the space.

The Hob Detection provides a reliable fast responding means of local detection above the hob well before the ceiling mounted heat detector which only operates after a fire has occurred.

In fire mode the LD1 Hob Detection will activate all the sounders in the apartment enabling the occupants to commence their evacuation earlier.

Activation of the Hob Detection in fire mode will cause the hob to be isolated and the sounders operated.

The LD1 Hob Detection provides additional intelligent to prevent a hob fire occurring, raise the alarm throughout the apartment and isolate the power supply to the hob.

Based upon the reliability of the LD1 Hob Detection system, the hob position and apartment size becomes irrelevant as part of an engineered solution where the hob risk is managed.

## LD1 Hob Detection

### Technical Sheet

Designed for Studio, Open Plan and Student Apartment's to reduce the kitchen hob risk and activate sounders throughout the apartment, thus allowing relaxation on the hob position and restrictions on the open plan area of the apartment.

#### MANAGING THE RISK BEFORE IT BECOMES A FIRE.

'LD1 Hob Detection' forms an extension of the intelligent apartment LD1 ceiling mounted detectors to provide local detection and management of the cooking hob.

Hob Detection in 'monitor mode' is designed to provide enhanced early detection at the hob and activates a warning alarm.

In 'fire mode', the power supply to the hob is isolated prior to a fire occurring and the ceiling mounted sounders throughout the apartment are activated.

The hob detection provides an earlier response over that of the ceiling mounted heat detector thus improving detection times and as it forms an extension of the LD1 detection system, the sounders are activated resulting in the occupants moving earlier.

Hob Detection works by monitoring the hob constantly for cooking activity. This includes infrared for monitoring radiant & conducted energy, time, power consumption, movement combined with sophisticated algorithms as required by the BS EN Standard. The system will initially raise a pre warning 15 second alarm in 'monitor mode' when conditions approach an unacceptable level. Where no action is taken or conditions become critical, the Hob Detection is activated in 'fire mode' to isolate the hob power supply preventing ignition and activating the apartment sounders .



Hob Detection comes from Norway & Finland where the Building Regulations equivalent require all kitchen hobs to be fitted with a monitoring Hob Detection in accordance with the British Standard BS EN50615:2015 'Hob Fire Prevention Standard', resulting in reduced numbers of cooking incidents since its introduction.

The system gives Fire Engineers a system to assist in presenting a case for managing the risk areas out, allowing greater flexibility with open plan apartments regardless of the floor area.

#### Stock Codes

- DMS432AB : 32 amp LD1 Hob Control Unit
- DMS101 : Ionisation intelligent smoke detector (alkaline)
- DMS102 : Optical intelligent smoke detector (alkaline)
- DMS103 : Intelligent heat detector (alkaline)

20/5

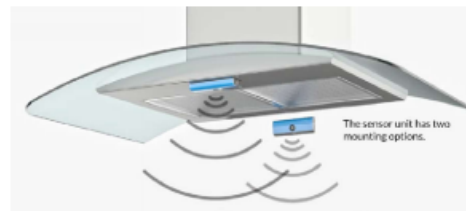

### Features

Hob Detection prevents hob fires occurring by constantly monitoring the hob and isolating the power supplies prior to a fire occurring in accordance with BS EN50615:2015.

Allows trade off in studio apartments giving greater flexibility with the hob positions.

Allows kitchen to be part of the open plan in LD1 & sprinklered apartments exceeding 32m<sup>2</sup> in area as restricted by BS9991:2015.

Activation of Hob Detection in 'fire mode', operates the apartment LD1 sounders.

Hob Detection is tested and certificated for 32 amp hobs to show compliance with the British Standard BS EN50615:2015.

Intelligent LD1 Smoke & Heat Detectors to BS 5446-2 and BS5839.

System manually reset's after activation and is ready to protect the hob and kitchen again.

Only maintenance is replacing the AA batteries every 3 years.

Failsafe to isolate the hob power supply where unit is removed or no power to the batteries.



37m<sup>2</sup> Studio Apartment (no sprinklers)

[www.dmsolutions.co.uk](http://www.dmsolutions.co.uk)

---

## Appendix B – Kitchen Hob Protection Review



**fds consult**

## **Kitchen Hob Protection Review**

**Application to Electric Hobs**

Issue 02  
**Appendix B**

April 2017

## **CONTENTS**

- 1.0 INTRODUCTION
- 2.0 ANALYSIS OF THE PROBLEM
- 3.0 STANDARDS
- 4.0 REVIEW OF THE PRODUCT MARKET
- 5.0 CONCLUSIONS

APPENDIX AA – BS EN50615:2015 COMPLIANCE TEST REPORT

This report has been prepared for the sole benefit, use and information of DM Solutions Ltd and the liability of FDS Consult Limited, its Directors and Employees in respect of the information contained in the report will not extend to any third party.

Issue	Date	Amendment Details	Author	Checked
00	16/03/2016	Initial report for comment	GS	GH
01	16/04/2016	Report updated	GS	GH
02	16/04/2017	Report updated	GS	HB
<b>Distribution</b>				
DM Solutions Ltd www.dmsolutions.co.uk				

© **FDS Consult Limited**

This report is formulated on the basis of the information and experience available at the time of preparation. It is applicable to the above-mentioned project only in accordance with the client's instructions. It is only valid provided no other modifications are made other than those for which a formal opinion has been sought and given by FDS Consult Limited.

FDS Consult Limited  
 152-154 London Road  
 Greenhithe  
 Kent  
 DA9 9JW

Tel: +44 (0) 1322 387411  
 Fax: +44 (0) 1322 386361  
 Web: www.fdsconsult.com



## 1.0 INTRODUCTION

This report is intended to identify the risk of kitchen hob fires, identify relevant standards for hob preventive systems and provide information on a suitable product for protecting the kitchen Hob to meet the identified standard, so safe escape can be achieved from the kitchen area.

This report will also provide technical information on the solution product allowing the approval authorities to understand the concept.

## 2.0 ANALYSIS OF THE PROBLEM

Analysis on fires in England is documented by the Department for Communities and Local Government and is based upon statistical information provided by the Local Authority Fire and Rescue Services.

The April 2014 to March 2015 statistics provides the following headlines:

- There were 258 fire fatalities in England in 2014 to 2015.
- 63 per cent of all fire fatalities were in accidental dwelling fires.
- There were 3,235 non-fatal fire hospital casualties.
- Local authority fire and rescue services attended around 154,700 actual fires in England in 2014 to 2015.
- 44 per cent of all incidents attended were fire false alarms.
- There were 28,200 accidental dwelling fires.
- 61 percent of domestic fires occurred in the kitchen.
- 52 percent of domestic fires were caused by the cooking appliances.

It can be concluded from the above that the cooking appliances account for the majority of domestic fires in England. Unfortunately this is not broken down further between hobs and ovens, but from conversation with experienced fire fighters the majority reference hobs as the greater risk. This is further documented on Fire Brigade Organisations web sites which have campaigns for kitchen fires which concentrate on hob fires.

The fires identified in the above statistics would be within domestic properties constructed in accordance with the Building Regulations. This includes kitchen compartmented properties, open plan properties and studio properties.

It is clear from the above statistics that additional measures should be provided to minimise cooking appliance fires, which would reduce the above figures and allow greater trade-offs for open plan and studio properties.

### 3.0 STANDARDS

On reviewing fire systems in England, we were unable to identify a specific approved solution for preventing kitchen hob fires. There are products on the market which claim to extinguish the hob fire once it occurs, but none of these are to a recognised British or European Standard.

Looking wider afield, we came across requirements for hob protection in the Nordic Countries, where they have experienced years of kitchen fires. The Regulators introduced a requirement for protection to be provided to all hobs so as to reduce the number of fires. This was introduced into their Building Regulation and similar Statutory Documents.

On the back of this requirement, a European Standard / British Standards was created that set standards for Household & similar electrical appliances. The BS EN Standard is known as BS EN50615:2015 Household & similar electrical appliances – Safety. Particular requirements for devices for fire prevention and suppression for electric hobs (cooktops).

The standard identified two categories of fire protection devices:

- Category A is concerned with extinguishing and simultaneous power cut off of the appliance.
- Category B is concerned with preventive power cut off of the appliance, preventing a fire occurring.

This report will only be concerned with preventing the fire occurring and therefore the Category B system test requirements will be reviewed below.

The standard requires the device to take measures to ensure that, as a result of unattended operation or excessive temperatures, fires caused by the cooking process are avoided and an alarm is raised locally.

The device should switch off the appliance before the fire starts and incorporate an audible warning device. An alarm of at least 65 dB measured 1m distance in accordance with EN 54-3 shall be generated.

All sensing devices that are only battery supplied shall give a visible and audible warning signal when the battery is approaching the end of life or in the case that they are wrongly mounted. In this situation the cooking appliance cannot be switched on. However, in each case that the user wants to start a cooking process, the error message needs to be confirmed by the user and the appliance is unlocked again.

The detecting device shall be held in place with reliable means, such that the device cannot be easily detached.

After removal for maintenance or cleaning, the fixing means shall be such that the device can only be remounted in the original position. This is to be achieved by a fixed secure back plate with reed switch, which will identify when the unit is in the correct position.

For a product to be certified as BS EN50615 compliant, the tests outlined in the Table 1 below must be carried out by an Accredited Testing House and passed for a Category B system.

## 11.104.2 Tests for Category B devices

	W Preparation	X Test	Y Test criteria / measurement
1	<p>Test 1 - Test device for false alarms</p> <p>Place pans (as in figure 101 of EN 60335-2-6) on all plates. Size of pans should equal size of plates. Fill all pans, except the largest one, with water (according to table 101 of part 60335-2-6). Fill largest pan with a quantity of sunflower oil as in table 11.Z105.</p>	<p>Heat all pans with water until water is boiling. Keep water simmering during the whole test. After all pans with water have been simmering for 20 minutes, start heating the largest pan (with sunflower oil) on full power with the aim to create fire</p>	<p>The device shall not cut off power to the cooktop or activate the extinguishing agent before the sunflower oil temperature reaches 200 °C, but it shall cut the power before the sunflower oil temperature reaches 330 °C.</p>
2	<p>Test 2 - Test device on all plates, one by one.</p> <p>Place pan (as in table 101 of EN 60335-2-6 and with dimension suitable to fit relevant plate) on the plate that is to be tested. Fill pan with a quantity of sunflower oil as in table 11.Z105. Place pans fitting to the diameter of the plates with a height of 15cm ± 2cm on all other plates. All plates should be tested, one at a time.</p>	<p>Set full effect on plate that is under testing with the aim to create a fire.</p>	<p>The device should cut off power to the cooktop before the sunflower oil temperature reaches 330°C (before fire starts). The sunflower oil shall not ignite within 10 minutes after the power to the cooktop has been cut.</p>
3	<p>Test 3 - Test device with cast iron pan (frying pan) on the plate with worst result during test 2.</p> <p>Place cast iron pan with dimension suitable to fit relevant plate on the plate that is to be tested. Fill pan with a quantity of sunflower oil as in table 11.Z105. Place tall empty pans with a height of 15cm ± 2cm on all other plates.</p>	<p>Set full effect on plate that is under testing with the aim to create a fire.</p>	<p>The device should cut off power to the cooktop before the sunflower oil temperature reaches 330°C (before fire starts). The sunflower oil shall not ignite within 10 minutes after the power to the cooktop has been cut.</p>

Table 1 – BS EN50615 Tests for Category B Devices

## 4.0 REVIEW OF THE PRODUCT MARKET

There are a number of solutions on the UK market ranging from fixed temperature sensors, PIR movement detectors and extinguishing units. None conform to the above British Standard.

Following review of suppression systems which require yearly maintenance, it was clear once the properties become occupied, no maintenance is carried out. Experience has also shown, that following a discharge, refilling of the suppressant canister does not occur, even in Student Accommodation which is managed.

With the above in mind it was felt a simple manual resetting system which turned the power supply off would provide a robust solution as it requires no 3<sup>rd</sup> party interaction in private properties, thus the decision to only progress with a Category B system.

As the BS EN50615 is the only reliable standard for hob protection, any product chosen needs to meet this standard in full.

Following a review of various products confirming to this standard, we decided to progress with the 'Hob Guard Safera Airis' here after called Hob Guard Safera'. This product meets all the BS EN50615 requirements and has a proven track record.

### 4.1 Hob Guard Safera Technical

The Hob Guard comes from Finland where they have years of experience of house fires as a result of the mainly timber construction. Their Building Regulations require hob guards to be fitted to hobs to prevent fires for typical cooking processes.

Hob Guard Safera has been tested for compliance with BS EN50615 by SP Fire Research ([www.spfr.no/services/fire-testing/stove-guards](http://www.spfr.no/services/fire-testing/stove-guards)) which is the largest independent research organisation in Norway similar to BRE in England. The unit is also CE marked in accordance with the EC directives.

A copy of the summary test certificate is provided in Appendix AA of this report and the full text report can be made available on request.

The Hob Guard prevents hob fires occurring by constantly monitoring the hob temperature and movement by sophisticated algorithms which can identify between safe and unsafe cooking practices and avoid false alarms.

The system will initially sound a 15 second sounder at 65dBa if it is getting too hot, temperatures rising too quickly, unusual electrical current change, or the hob is left unattended with no cooking source or hazardous conditions are present. If no action is taken within the 15 seconds, the system will go into shut down mode by automatically turning the hob off with the sounder continuing to operate. Where the sounder activation is due to an unusual cooking process, the Occupant simply presses the reset button on the Hob Guard above the hob allowing the system to be reset and continues monitoring the hob. The Occupant is managing the process with the necessary audible alarm provided warnings as necessary.

Hob Detection works by monitoring the hob constantly for cooking activity as shown in Figure 1 below. This includes infrared for monitoring radiant & conducted energy, time, power consumption, movement combined with sophisticated algorithms as required by the BS EN Standard.

Based on the data from the sensors, the Hob Detection recognises both cooking and hazardous situations and reacts accordingly so as not to interrupt the normal cooking process.

The unit is manually reset after activation and ready to protect the hob again unlike suppressant system which would require recharging, which rarely occurs.

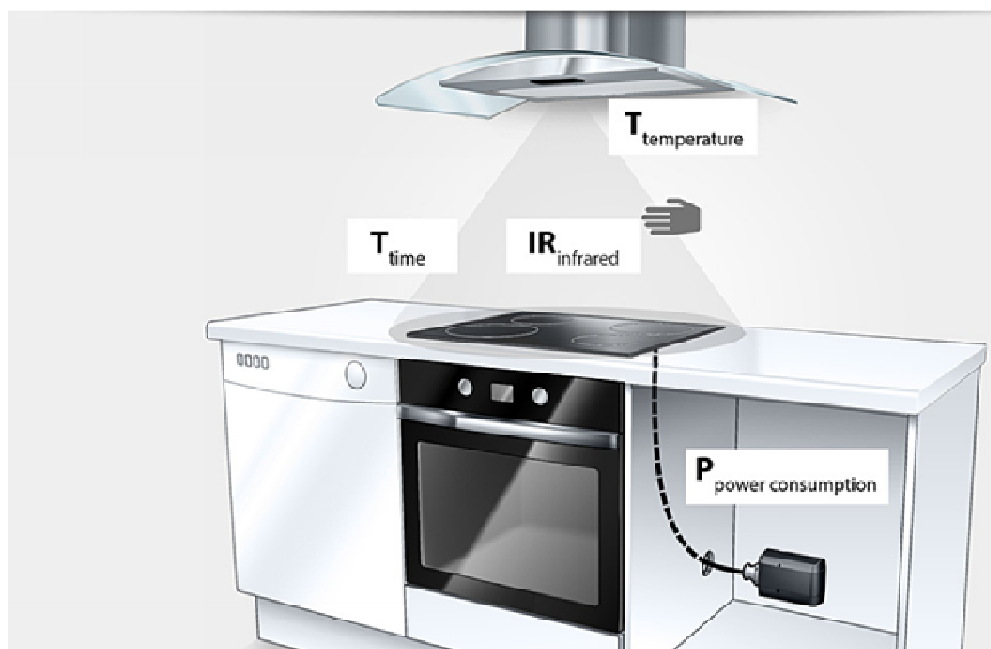

**Figure 1 – Sensing Elements**

A graphical demonstration of the sensors can be seen in the '[Hob Guard Intelligence Video](http://www.dmsolutions.co.uk)'. (www.dmsolutions.co.uk).

A demonstration of the system operating compared to a traditional unmonitored hob, to prevent a fire occurring can be seen in the '[Hob Guard Fire Video](#)'.

Our research indicated the Hob Guard is already installed in thousands of kitchens across Europe and since these installations, none of the owners have ever reported a hob fire. Hob Guard does not interfere with normal cooking and doesn't require any maintenance, other than a quick clean of the sensor from time to time.

The hob sensor AA batteries need to be changed every three-years which isolates the power to the hob until such time as this occurs.

We have also visited the organisation that researched and developed the product to witness the operation.

In summary the Hob Guard is provided to protect the hob, which will isolate the power to the hob prior to ignition occurring in accordance with the British Standard BS EN 50615. As the detection unit is located 600mm above the hob, it provides local detection to the hob. The hob guard unit will sound the unit alarm.

The unit is intended to prevent a hob fire occurring, and provides local detection to raise the alarm earlier unlike the ceiling mounted heat detector resulting in earlier notification of an incident. In an incident this could be minutes and the hob guard will have isolated the power to the hob.

## 4.2 Hob Guard Safera Components

The Hob Guard Safera comprises of two components. One component is located above the hob with the second component located below the worktop as shown in Figure 2 below.



**Figure 2 – Component Locations**

The Hob sensor component can be located above the hob on the extractor unit or fixed to the back wall as shown in Figure 3. The battery operated unit connects with the hob control unit by way of a wireless 2 way connection designed for safety critical applications. If the power supply is lost to the sensor, batteries are removed or the unit is removed during the filter cleaning and not repositioned correctly, the hob will close down within two to three minutes becomes fail safe off.

The hob sensor measures 130mm x 45mm x 20mm deep and comes in 10 different colours.

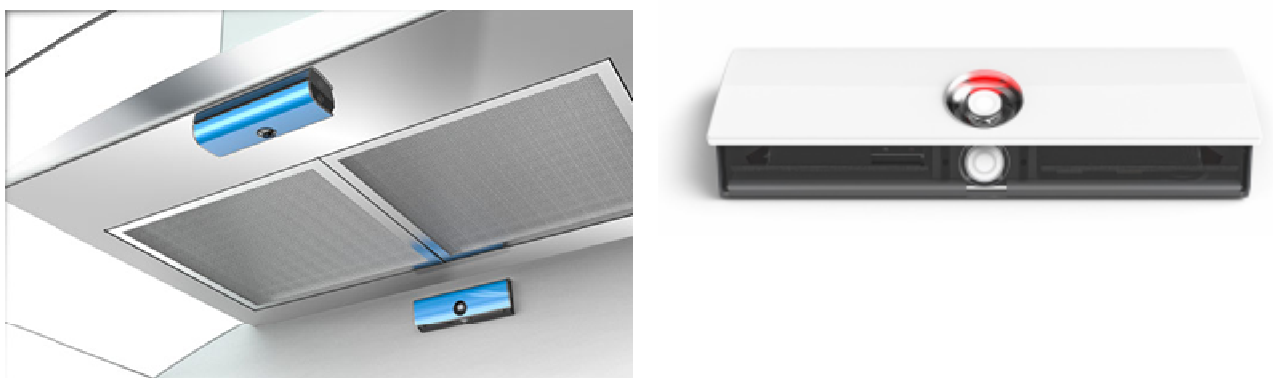

**Figure 3 – Hob Sensing Element**

The sensing unit mounting criteria are as below.

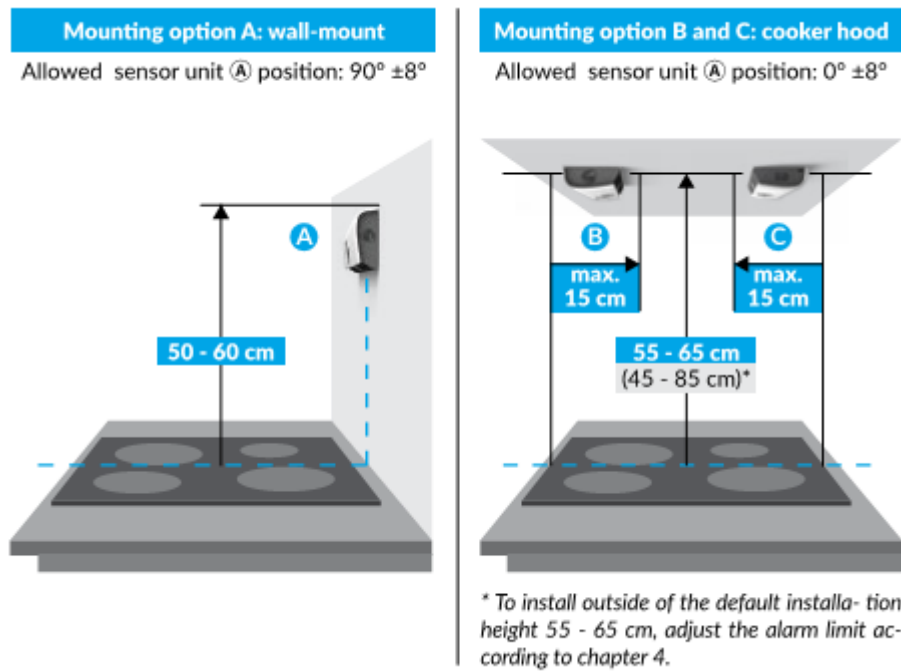
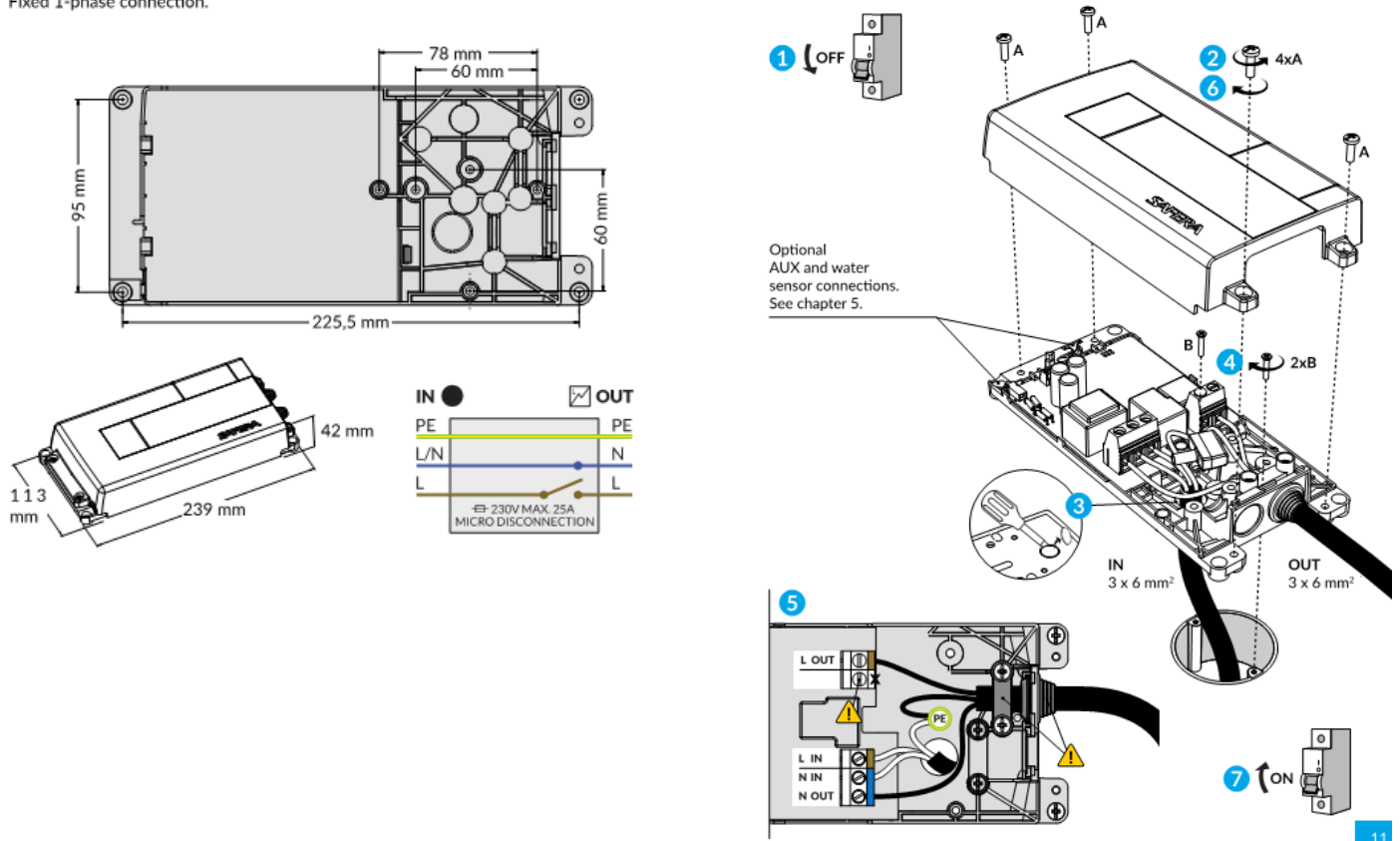

**Figure 4 – Sensing Element Position**

The electrical control component is located below the worktop and is used to monitor the current and isolate the power to the hob in an alarm condition.

The hob mains are wired into the control box with the switched output connected to the hob cable. The device gains the necessary power from the hob cable.

Fixed 1-phase connection.



**Figure 5 – Electric Control Box**

The electrical control unit measures 239 x 113 x 42mm and can be located in cupboard or behind the kick board below.



## 5.0 TYPICAL QUESTIONS

The following identifies typical questions asked about the Hob Guard unit.

### Q: How can the system detect a fire before the ignition of a fuel source takes place?

A: The system is based on four sensors and intelligence system to react quickly to various hazards while cooking, and the best way to understand how the system is working in real life is to look at the tests required to pass in the standard BS EN 50615 and how the system has actually performed in those tests.

This is best understood by reviewing the test below and Table 1 – BS EN50615 Tests for Category B Devices" where the tests 2 and 3 are explained.

Test results							
<p>The performance of the stove guard was tested according to EN 50615:2015, section 11.104 for Category B devices. The stove guard was tested using a hob with 4 elements.</p> <p>As the sensor is based on infra-red reading of the temperature of the surface of the vessel, the function is dependent on a satisfactory view-factor. Based on this, the lowest height specified in the installation manual was assessed to be the most unfavourable position and therefore all tests were performed with the sensor placed 50 cm above the surface of the hob.</p> <p>In all tests, logging was started when heating of the oil-containing vessel was initiated.</p>							
<h3>3.1 Testing with 4-element hob</h3> <p>Stove guard installation height: 50 cm Sensibility setting: 6</p> <p>All tests were performed with range hood switched on.</p> <p><i>Table 4: Results from testing of Siro Airis with a four element hob.</i></p>							
Test	Test criteria category B	Element	Test ID	Oil temperature at power cut-off [°C]	Ignition within 10 minutes [yes/no]	Criteria met [yes/no]	
1	Test device for false alarm	Rear left	1A	231	No	Yes	
2	Test device on all plates, one by one	Rear left	2A-1	181	No	Yes	
		Rear right	2A-2	192	No	Yes	
		Front right	2A-3	250	No	Yes	
		Front left	2A-4	285	No	Yes	
3	Test device with cast iron pan on plate with worst result from test 2	Front left	3A	255	No	Yes	

Here it can see when the product cuts off the power and how the oil temperature raise has been stopped before it reaches 330°C which is the limit to pass the BS EN 50615 tests (it has been chosen so that there is a safe margin before oil self-ignition temperature).

**Q: Also if the system depends on a rise in temperature around the hob how does it differentiate between the normal rise in cooking temperature for frying or braising and a potential ignition source; has a study been done on the occurrences of false alarms from the system?**

A: There are several algorithms and sensors used to prevent false alarms also because it is critical to user acceptance. In the standard BS EN 50615 there is a specific test for testing the product's ability to avoid false alarms: as shown below.

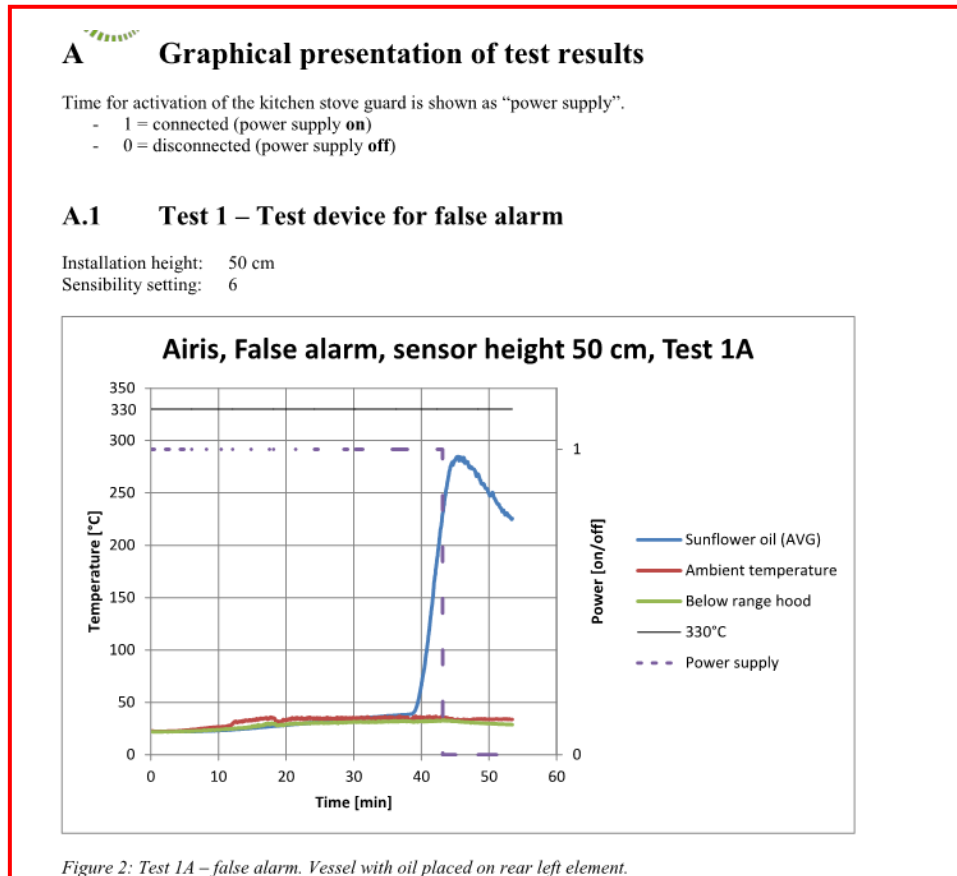

This test is very good false alarm test but it is also a good test to see the overall performance of the product, because at the end of the test the system is also required to prevent the hazard created with the fourth pot - basically the system is simultaneously avoiding a false alarm and preventing an actual hazard.

**Q: Also if the system simply cuts of power to the hob, some electric hobs take a time to cool down and could still provide an ignition source to a fuel adjacent to a hob?.**

A: This has been taken care in the standard. Item 2.2 of the test certificate shows the type of the hob used which is cast iron which would continue to hold the heat after power isolation.

## 2.2 Hob

The tests were performed using a hob with cast iron elements as described in EN 60335-2-31, section 11.2 installed in a base cabinet as described in EN 50615. The hob comprise 3 units of the type Siemens ET 13051, each consisting of one 2 kW rear element and one 1.5 kW front element, see Picture 1.

All tests were performed with 2 units forming a 60 cm hob with 4 elements.

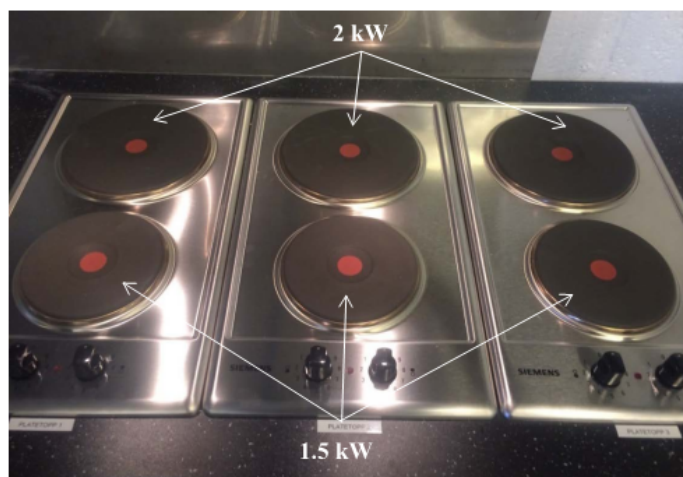

Picture 1: Test hob.

The image below shows the pan used in the tests. The hob (cast iron) and the pan (thick cast iron) have been especially chosen to the tests because these type of hobs and cooking vessels create the worst case scenario for the temperature rise after power cut off.

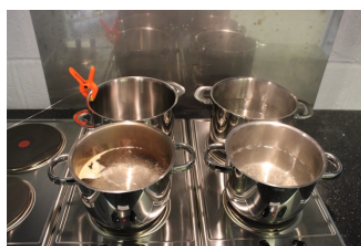

Picture 4: False alarm test with 4 elements. Vessel with oil placed at rear left element.



Picture 6: Cast iron pan used during tests.



Picture 5: Test with cast iron pan placed on front right element.

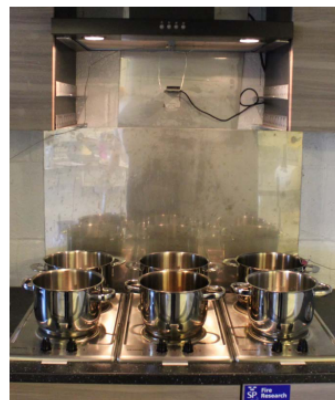

Picture 7: Test set up with 6 element hob.

## 6.0 CONCLUSION

The Department for Communities and Local Government statistical demonstrate that 52% of domestic fires were caused by the cooking appliances.

The British Standard BS EN50615 is relevant to preventing kitchen hob fires.

The BS EN50615 standard requires the penetrative device to:

- raise a pre warning alarm,
- have the ability to disconnect the hob from the electricity supply before a fire starts,
- have the ability to cut off the hob electricity supply before the temperature reaches a dangerous level,
- ensure that the electricity cut-off is not be triggered by a false alarm.

On reviewing the various systems on the market it was found the Hob Guard Safera proofed to be the most reliable product on the market and meets the BS EN50615 in the prevention of hob fires.

The Hob Guard Safera provides a reliable method of preventing hob fires and removing the hob risk from the space.

The Hob Guard Safera also provides a reliable fast responding means of local detection well before the ceiling mounted heat detector.

Based upon the reliability of the Hob Guard Safera, the hob position becomes irrelevant as part of an engineered solution.

**Appendix AA EN50615:2015 COMPLIANCE TEST REPORT (Summary)**

The full detail Test Report can be made available upon Request.



## Test report – SAFERA Airis

EN 50615:2015 Household and similar electrical appliances – Safety.  
Particular requirements for devices for fire prevention and suppression  
for electric hobs (cooktops)

SP Fire Research AS



SPFR Report 20005-04



## Test report – SAFERA Airis

EN 50615:2015 Household and similar electric appliances – Safety. Particular requirements for devices for fire prevention and suppression for electric hobs (cooktops)

<b>VERSION</b> 1	<b>DATE</b> 2015-09-29	
<b>AUTHOR(S)</b> Roger Mårvik		
<b>CLIENT(S)</b> Safera Oy	<b>CLIENT'S REF.</b> Samuli Lintonen	
<b>PROJECT NO.</b> 20005-04	<b>NUMBER OF PAGES/APPENDICES:</b> 9 incl. 3 appendices	
<b>TEST OBJECT</b> Kitchen stove guard	<b>TEST OBJECT RECEIVED</b> 2015-02-25	
<b>TEST PROGRAM</b> EN 50615 - functionality	<b>TEST LOCATION</b> SP Fire Research AS	<b>DATE OF TEST</b> 2015-03-10 to 2015-03-11.

### ABSTRACT

Stove guard SAFERA Airis with Power Control Unit PCU5.1-P has been tested and found to comply with the performance requirements according to EN 50615:2015 for Category B devices.

Included in this is also the stove guards Garo SR3 AND Athena Nordic Spisec AddOn.

Sound level of audible warning has been measured and found to comply with the requirements for EN 54-3:2014.

Protection in case of removal/relocation of sensor or important parts of the device has been tested and found to comply with the requirements of EN 50615:2015.

The test results relate only to the items tested

<b>PREPARED BY</b> Roger Mårvik	<b>SIGNATURE</b>
<b>APPROVED BY</b> Christian Sesseng	<b>SIGNATURE</b> 
<b>REPORT NO.</b> 20005-04	<b>CLASSIFICATION</b> Restricted

# EC/EEA DECLARATION OF CONFORMITY



The undersigned, representing the following manufacturer  
 SAFERA Oy, Muuntotie 1 C1 FI-01510 Vantaa Finland

herewith declares that the products  
 SAFERA Airis

are in conformity with the provisions of the following EC directives

Ref. no	Title
2006/95/EC	Low Voltage Directive
2004/108/EC	Electromagnetic Compatibility Directive
1999/5/EC	Radio and Telecommunications Terminal Equipment Directive
2002/95/EC	Directive Regarding the Restriction of the Use of Certain Hazardous Substances in Electrical and Electronic Equipment
2002/96/EC	Waste Electrical and Electronic Equipment (WEEE)

and that the following standards and/or technical specifications have been applied

Ref. no	Title
EN 50615, category B	Household and similar electrical appliances. Safety. Particular requirements for devices for fire prevention and suppression for electric hobs (cooktops)
EN 301 489-1: 2011 (V1.9.2)	Electromagnetic compatibility and Radio spectrum Matters (ERM); ElectroMagnetic Compatibility (EMC) standard for radio equipment and services; Part 1: Common technical requirements
EN 301 489-17: 2009 (V2.1.1)	Electromagnetic compatibility and Radio spectrum Matters (ERM); ElectroMagnetic Compatibility (EMC) standard for radio equipment; Part 17: Specific conditions for Broadband Data Transmission Systems
EN 55014-1:2000 / CISPR 14-1	Electromagnetic compatibility - Requirements for household appliances, electric tools and similar apparatus - Part 1: Emission
EN 55014-2:1997 / CISPR 14-2 + Amd.2	Electromagnetic compatibility - Requirements for household appliances, electric tools and similar apparatus - Part 2: Immunity - Product family standard
ETSI EN 300 328: 2012 (V.1.8.1)	Electromagnetic compatibility and Radio spectrum Matters (ERM); Wideband transmission systems; Data transmission equipment operating in the 2,4 GHz ISM band and using wide band modulation techniques
EN 60730-1: 2000 + A12 + A13 + A1 + A14 + A16 + A2	Automatic electrical controls for household and similar use, Part 1: General requirements
EN 60730-2-9: 2010	Automatic electrical controls for household and similar use, Part 2-9: Particular requirements for temperature sensing controls
EN 60335-1: 2010 (ed 5.0)	Safety of household and similar electrical appliances, Part 1: General requirements
EN 60335-2-31: 2002 / A1:2006	Safety of household and similar electrical appliances, Part 2-31: Particular requirements for range hoods.

Vantaa Finland 1.5.2015



Henri Andell, CEO

V4.6.0. ENG



**SAFERA**  
 SAFETY WITH STYLE



## Design Note No. Appendix C

**Project** Summary of BRE Research Report  
204505 on Effectiveness of Sprinklers  
in Residential Premises

**Date** 2<sup>nd</sup> January 2016



### 1.0 DOCUMENT CONTROL

Issue	Date	Description	Author	Reviewed
1	02/01/2016	Issue of Design Note	GS	GH

### 2.0 INTRODUCTION

The following Design Note summarises the part of the Building Research Establishment (BRE) research work, for compartment fires within residential properties. It is not research carried out by FDS Consult and it is acknowledged all references are copyright to the BRE.

The relevant section of the research for compartment fires is documented below to demonstrate the benefits of residential sprinklers and provided a summary so an easy comparison can be drawn between sprinklered and unsprinklered residential buildings.

### 3.0 RESEARCH BACKGROUND

Prior to the introduction of Residential Sprinklers in the Approved Document B (ADB) in 2006, they were the subject of much debate as it was believed they offered a means of saving lives in domestic properties and assisted Fire Fighters in their operations. In the lead-up to the updating and issue of the ADB 2006, the BRE was commissioned by the Office of the Deputy Prime minister (ODPM) in 2002 to carry out a two and a half-year study of the effectiveness of sprinklers in residential premises which was published in 2004. The work had a number of objectives, but the relevant work to this Design Note was to carry out an experimental program to examine and quantify the effectiveness of residential sprinklers, in particular with regards to life safety in the compartment room of origin.

The benchmark fire tests essentially involved burning a stylised, representative fuel package of simulated furniture with wall and ceiling linings arranged inside a simulated residential room.

### 4.0 TEST BUILDING

Eight sprinklered and unsprinklered lounge fires using realistic fuel arrays were conducted inside the BRE Test House, Cardington which was a two-storey detached house of traditional design. The ground floor comprised of a lounge (4m x 3.5m x 2.4m high), a kitchen, dining room and a hallway. The first floor comprised two bedrooms and a bathroom area. There was a straight flight of conventional tread stairs.

The lounge and main bedroom were double glazed and were closed for the tests. Inside the lounge, there was a chimney and two low level air bricks. The door of the main bedroom was partially open, with the door of the bathroom, the dining/kitchen, back bedroom/landing and kitchen/hallway closed and sealed.



The effect of the lounge/hallway door (open/closed), water flow rate, sprinkler orientation and sprinkler model (two 15mm pendent types) were studied. The sprinkler water flow rates were 60 l/min for a single sprinkler and 84 l/min for two sprinklers operating.

The fire compartment essentially comprised of a residential room with a timber structure supporting plasterboard walls and a ceramic fibre board ceiling. The facility was configured to both open and closed door conditions.

Smoke alarms were located inside the lounge, hall and landing and were replaced after every fire.

The fuel was conditioned prior to each test and the house was allowed to dry out between tests.

## 5.0 FULL SCALE FIRE TEST

As summarised above the testing was carried out at the BRE Test House, Cardington.

Various tests were carried out, however this Design Note is only concerned with a lounge compartment fire with the internal doors open. After reviewing the same fire tests with the internal doors closed, it was not considered to represent a worst case condition as the fire was smaller with lower gas temperatures and the gases were confined to the closed room.

Figure 1 below shows the lounge to be considered, which contained a TV, sofa, chairs, coffee table, shelf unit and curtains representing a typical lounge. A window was located behind the TV with the internal door to the bottom left which led onto the entrance hall. The room dimensions were 4m long x 3.5m wide (door to arm chair) x 2.4m high.

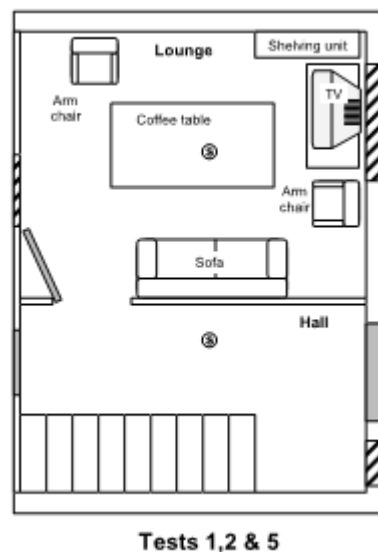

**Figure 1 – Lounge Setup**

The lounge is located at ground floor within the house as shown in Figure 2 below. The figure also shows the location of the various testing recording equipment so as to allow conditions to be monitored.

Figure 3 shows a summary of the test stages and observations during the tests.

The graphs in Figure 4 show the temperatures in the various rooms at ceiling level during the tests.

The graphs in Figure 5 show a summary of the temperatures in the various rooms at head height (1.8m) during the tests.

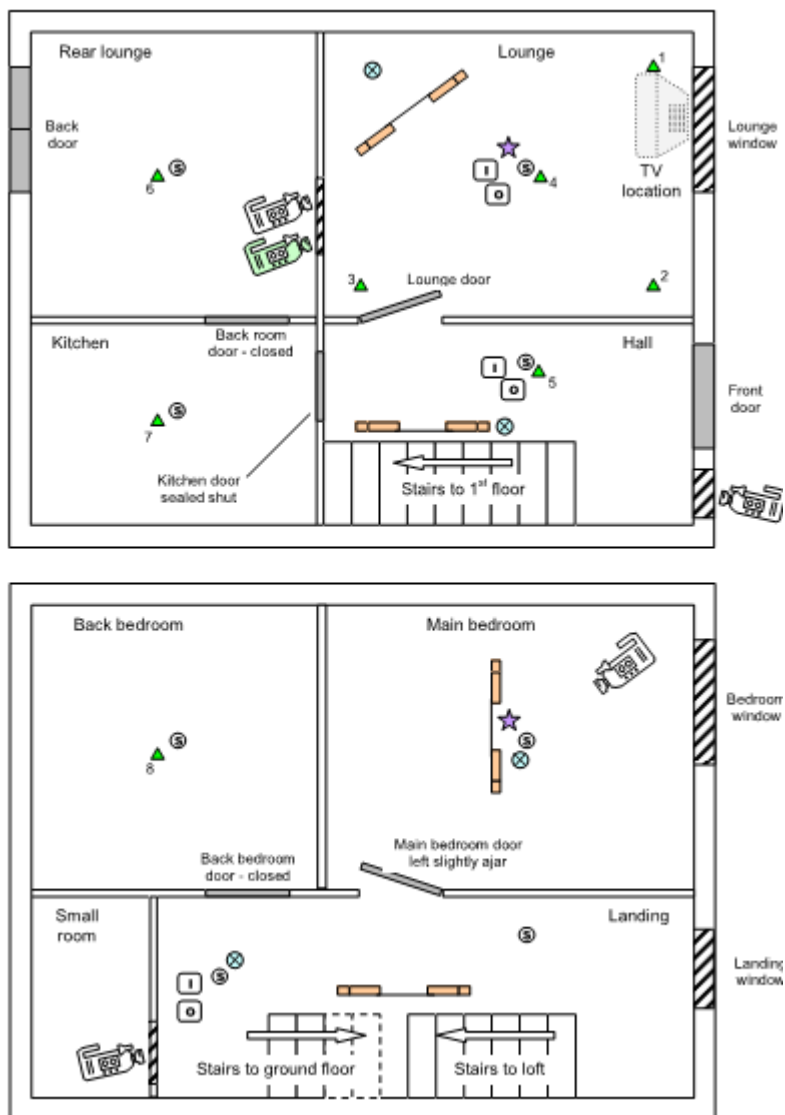

Figure 2 – Test House Layout

Test	Test 1 Unsprinklered	Test 2 Sprinklered
<b>Test designation</b>	HF01 – House fire test 1	HF02 – House fire test 2
<b>Test date</b>	14/02/03	17/02/03
<b>Test description</b>	Open lounge door, unsprinklered	Open lounge door, unsprinklered
<b>Test location</b>	Lounge, Cardington test house	Lounge, Cardington test house
<b>Sprinklered test</b>	No	Yes
<b>Sprinkler operation</b>	N/a	One sprinkler operated
<b>Water flow rate</b>	N/a	60 l/min
<b>Main fuel source</b>	24"TV	27"TV
<b>Ignition source</b>	Tea light candle with 60 seconds pre-burn	Tea light candle with 60 seconds pre-burn
<b>Ignition source location</b>	Under front LHS edge of TV, if facing TV screen	Under front LHS edge of TV, if facing TV screen
<b>TEST OBSERVATIONS</b>		
<b>Prior to test</b>	Humidity 38.5% at 13.5°C inside lounge	Humidity 41.2% at 12.6°C inside lounge
<b>Not noted</b>	TV starts to burn	
<b>00 min 00 s</b>		Ignition
<b>02 min 10 s</b>		Flame too far from TV to get it burning. Tea light raised by 15mm on wood strip
<b>02 min 50 s</b>	First detector operated in the lounge	
<b>02 min 45 s</b>		TV starts to burn
<b>04 min 11 s</b>		First detector operated in the lounge
<b>04 min 35 s</b>		Flames to top of TV
<b>04 min 58 s</b>		TV tube blown
<b>05 min 06 s</b>		Second detector operated in the hall
<b>06 min 03 s</b>	Flames to top of TV	
<b>06 min 50 s</b>	TV tube blown	
<b>06 min 55 s</b>		Curtains on fire
<b>07 min 02 s</b>		Flames at top of curtain
<b>07 min 10 s</b>		Sprinkler operated
<b>08 min 00 s</b>		Curtain dropped
<b>09 min 40 s</b>	Fire starting to pick up	
<b>10 min 42 s</b>	Curtains on fire	
<b>10 min 55 s</b>	Flames half way up curtain	
<b>11 min 12 s</b>	Flames at top of curtain	
<b>12 min 22 s</b>	Curtain dropped	
<b>12 min 45 s</b>	Windowsill on fire	
<b>16 min 00 s</b>		Smoke noticed issuing out from chimney
<b>20 min 00 s</b>		End of fire
<b>21 min 00 s</b>	End of fire	
<b>SUMMARY OF POST TEST DAMAGE</b>		
	Whole TV damaged, damage to TV table, two curtains gone, windowsill above TV burnt and wooden shelving upright closest to TV burnt. Burning curtain scorched blanket on chair next to TV table. Sundries on shelving next to TV: glass vase cracked, videos on shelf melted, radio melted, newspapers scorched, toy melted. White painted walls sooty	A third of the TV damaged, slight damage to TV table, one curtain gone and presence of water

**Figure 3 – Fire Test Data**



fds consult

Figure 4 - Temperature Probes at Ceiling Level with Lounge door open

Unsprinklered Rooms (Test 1)

Sprinklered Rooms (Test 2)

Above the TV in Lounge (A)

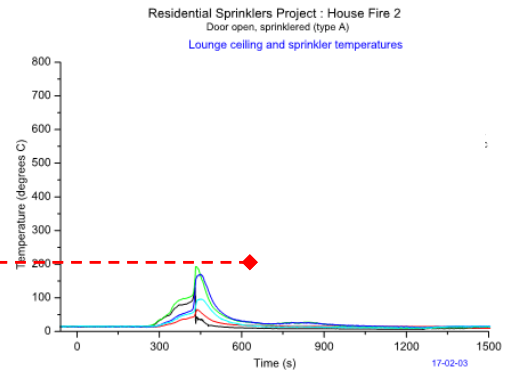
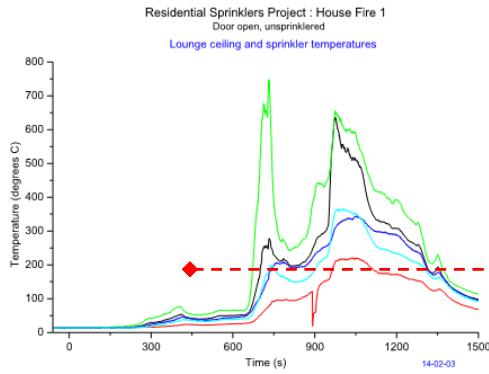

Behind lounge door (3.5m away from fire) (B)

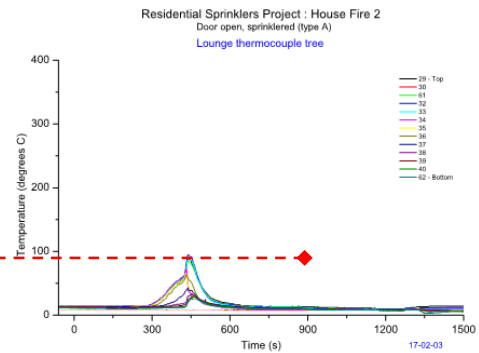
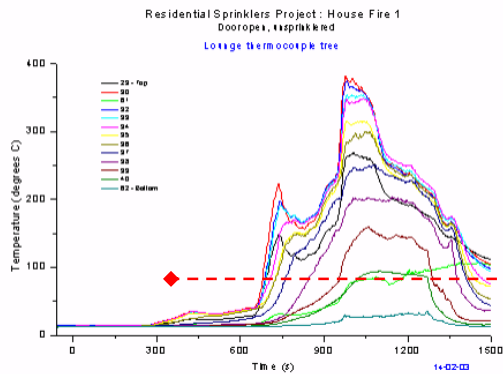

Hall (C)

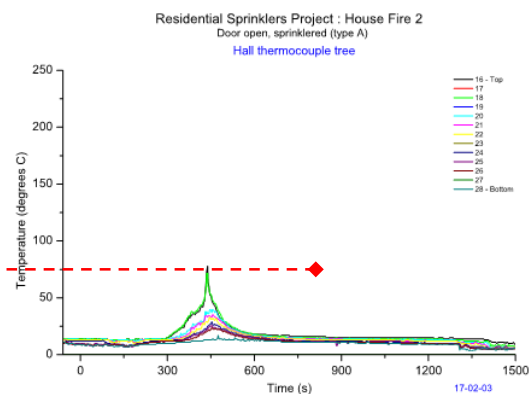
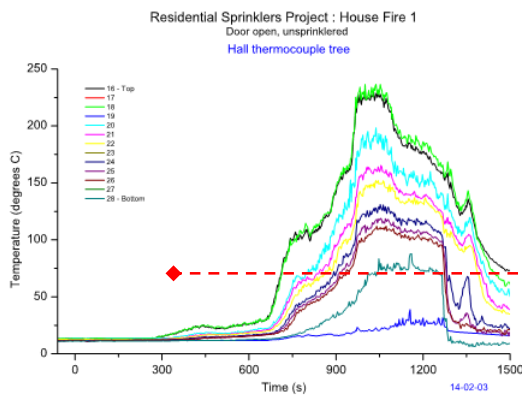

Landing (D)

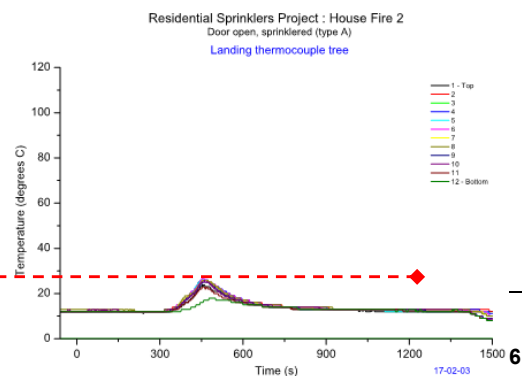
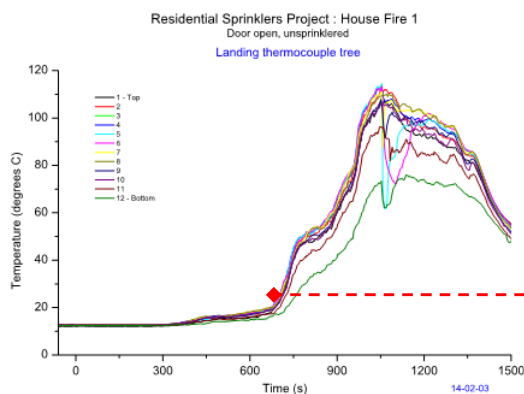

on Effective

Figure 5 - Temperature Probes at Head Height (1.8m) with lounge door open

Unsprinklered Rooms (Test 1)

Combined Graphs for the three spaces (E)

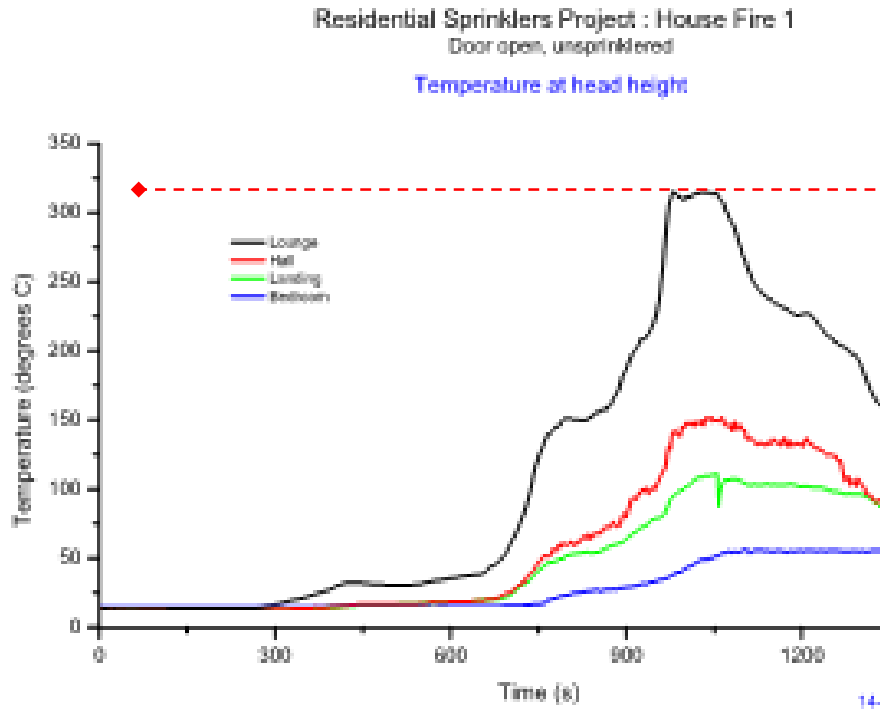

Sprinklered Rooms (Test 2)

Residential Sprinklers Project : House Fire 2  
Door open, sprinklered (type A)  
Temperature at head height

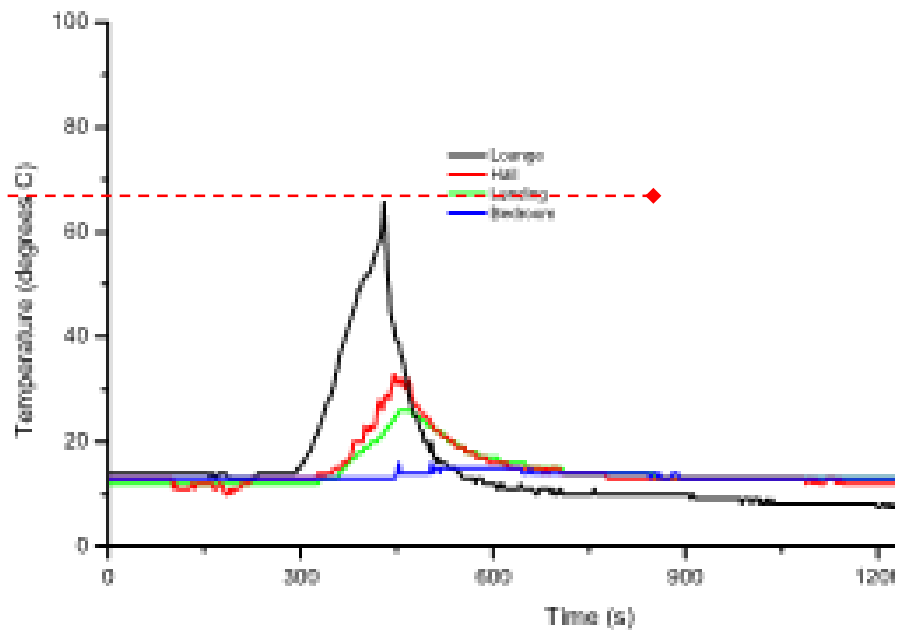



## 6.0 ANALYSIS OF TEST DATA RESULTS

The curves on each of the graphs in Figure 4, recorded at ceiling level, shows the temperatures recorded for each of the channels on the data loggers.

The curves on the graphs in Figure 5, recorded at head height, show the average temperatures recorded by the data loggers in each of the spaces for the sprinklered and unsprinklered condition.

Figure 6 below shows a summary of the maximum temperatures in each of the spaces for the sprinklered and unsprinklered condition when the internal doors were left open.

Test	Test 1 - Unsprinklered		Test 2 - Sprinklered	
	Ceiling Level (2.4m)	Head Height (1.8m)	Ceiling Level (2.4m)	Head Height (1.8m)
<b>Thermocouple Position</b>				
<b>Above TV</b>	720°C	-	200°C	-
<b>Behind Lounge Door</b>	350°C	325°C	90°C	65°C
<b>Hall</b>	230°C	150°C	75°C	30°C
<b>Landing, 1<sup>st</sup> floor</b>	150°C	100°C	29°C	23°C

**Figure 6 – Summary of Maximum Temperatures**

The temperatures in the above table clearly show the benefit of the sprinklers in residential properties which should help with means of escape and fire fighting operations.

As identified in Figure 3, the fire source for the sprinklered Lounge had to be repositioned at 2 min 10 s into the Test as ignition did not occur. To compare against the unsprinklered condition, this time would need to be reduced on the detector and sprinkler operating times identified in the graph and tables.

In the sprinklered lounge, the smoke detector operated at 4 min 11 seconds into the test. Adjusting for the above modification, this would be 2 minutes into the test.

In the sprinklered hall, the smoke detector operated at 5 min 6 seconds into the test. Adjusting for the above modification, this would be 3 minutes into the test.

The ceiling temperatures were approximately 30°C at the time of detection operation.

In the sprinklered lounge, the sprinkler head operated at 7 min 10 seconds into the test. Adjusting for the above modification, this would be 5 minutes into the test.

As sprinklers drench the area around the fire, once operated the fire load makes little difference as combustion would not be supported which is the principal of sprinklers.

With a high level of smoke detection in each of the spaces, it could be concluded that the means of escape should be completed prior to operation of the sprinkler head.

Test 2 shows that should an occupant be in a bedroom on the first floor, the gas temperatures would not hamper their escape down the stair unlike the unsprinklered condition.

Without any further analysis, using the hall temperature in the sprinklered Test, the expected temperature meeting the Fire Fighters at the front door would be approximately 30°C.

In the unsprinklered condition the expected temperature meeting the Fire Fighters at the front door would be approximately 150°C at 17 minutes into the fire.

The fires did not spread into the adjacent spaces.

The volume of the space would assist with reducing the gas temperatures.

It is recognised that the sprinklers used during the tests were of the pendant type which would have a lower RTI to that of the recessed sprinklers used in residential properties. However, the additional times would be seconds and when operated would quickly drench the area around the fire and assist with reducing the gas temperatures.

The double glazed windows remained in position during both Fire Tests.

After reviewing the Test with the lounge door closed, it was not considered to review any further, as it did not represent a worst case condition.

## 7.0 REPORT CONCLUSIONS

The unedited BRE Summary Document general conclusions of the house fire tests were as follows:

- For the unsprinklered fires, the fire damaged area was greater than when sprinklered.
- With sprinklers, the fire gases were cooled sufficiently that the occupants of the room of origin would not have experienced extreme pain due to convected heat.
- Loss of consciousness would not have occurred in the standard lounge with the door open, but would have occurred with the door closed. In all the sprinklered fires, death would not have occurred.
- In all the fires (with and without sprinklers), visibility was lost after 5 to 7 minutes. Sprinkler activation therefore had no effect on the visibility.
- The life safety benefits of fitting smoke alarms was demonstrated. This includes the added benefit of fitting linked smoke alarms in both rooms and circulation spaces.
- Tenable conditions (apart from visibility) for the rest of the house could be maintained by the sprinklers in the room of origin, or closing the door of the room of origin.
- Without sprinklers, it was estimated that occupants of the lounge would have lost consciousness, due to convected heat, and loss of consciousness due to asphyxiant, would have occurred within 1 to 2 minutes of each other. Death would follow about 1 minute after loss of consciousness. These observations were independent of the lounge door being open or closed.

## 8.0 CONCLUSIONS

The full scale document research was carried out by the BRE on the behalf of the ODPM, which led to the introduction of sprinklers in the Approved Document B in 2006.

The fire did not spread to the adjacent rooms in the unsprinklered condition.

As documented by the research, sprinklers will cool the gas temperatures within the fire space, which will assist with the means of escape and gas temperatures on commencement of fire fighting operations.

The document research should be used in association with CFD analysis as it represents a reality of what will happen unlike computer programs which will assume ideal conditions resulting in worst case modelling conditions and cannot take the cooling effect of sprinklers into consideration.

